

PYROSPOT DGE 10N

Pyrometers for Industry and Research



- **Digital pyrometer for 100 °C to 1200 °C**
- **Short response time from 2 ms**
- **RS485 interface**
- **Display and keyboard**
- **Vario optics with aiming light or through-lens sighting**

The digital pyrometers PYROSPOT DGE 10N are especially designed for industry and research applications. The devices are suitable for temperature measurement from 100 °C of many different surfaces for example metals, ceramics or graphite.

The solid construction in form of a compact housing with protection window for optics allows usage even under rough environmental conditions.

With a short response time of only 2 ms (t95) these pyrometers are also suitable for fast measuring processes.

The vario optics with quartz glass protection window realise measuring field diameters from 1.2 mm.

The integrated LED or laser aiming light or, alternative, the through-lens sighting, enables to focus the measuring object exactly.

The temperature linear standard output signal of 0/4 to 20 mA allows easy implementation in existing measuring and controlling systems.

The device is equipped with integrated, galvanically isolated RS485 interface which allows parameterising and software evaluation even in bus systems.

The emissivity is also adjustable via push-buttons and display directly on the device. All parameters can be easily adjusted to the application by using the comfortable parameterizing and evaluation software PYROSOFT Spot.

Typical pyrometer application areas:

- Steel industry
- Kiln engineering
- Hardening
- Welding
- Metal industry

Technical Data and Accessories

Technical data		
Type	DGE 10N	DGE 10N
Temperature ranges	100 °C to 850 °C	150 °C to 1200 °C
Sub temperature range	adjustable within temperature range, minimum span 50 °C	
Spectral range	2.0 μm to 2.6 μm	
Optics	vario optics with quartz glass protection window	
Distance ratio	100 : 1	200 : 1
Measurement uncertainty	0.5 % of meas. value + 2 K ($T_U = 23\text{ °C}$, $\varepsilon = 1$, $t_{95} = 1\text{ s}$)	
Reproducibility	0.3 % of meas. value + 1 K ($T_U = 23\text{ °C}$, $\varepsilon = 1$, $t_{95} = 1\text{ s}$)	
NETD ¹	0.5 °C ($T_U = 23\text{ °C}$, $\varepsilon = 1$, $t_{95} = 1\text{ s}$)	
Response time (t ₉₅)	2 ms, adjustable up to 10 s	
Emissivity	0.050 to 1.000, adjustable via interface or push-buttons directly on the device	
Storage	maximum value storage, adjustable via interface	
Output	0/4 to 20 mA, adjustable via software, temperature linear, max. burden: 500 Ω	
Interface	RS485, galvanically isolated, half duplex, max. 115 kBd	
Aiming	LED or laser aiming light or through-lens sighting	
Software	PYROSOFT Spot for Windows®	
Parameters	emissivity, response time, temperature unit °C or °F, storage, sub range, adjustable via interface and software	
User controls	emissivity control push-buttons (resolution 0.001), aiming light push-button, display	
Power supply	24 V DC ± 25 %	
Power consumption	max. 1.5 W	
Operating temperature	0 °C to 45 °C	
Storage temperature	-20 °C to 70 °C	
Weight	approx. 520 g	
Dimensions	54 × 54 mm, length 170 mm	
Housing	compact housing with plug connector, display, push-buttons and optics protection window	
Safety class	IP 65 (DIN 40 050)	
CE symbol	according to EU regulations (EN 50 011)	
Scope of delivery	PYROSPOT DGE 10N, manual, inspection sheet, PYROSOFT Spot for Windows® (without connecting cable, please order separately)	

¹ noise equivalent temperature difference



Accessories, mechanical, electrical and optical ¹	
Connecting cable 12-pin	length 2 m, 5 m, 10 m, 15 m, 20 m, 25 m or 30 m
Interface module	RS485 to USB
Power supply	24 V DC, 0.6 A
Mounting angle	adjustable, stainless steel
Ball and socket mounting	adjustable, stainless steel
Air purge unit	stainless steel, air pressure 0.1 to 0.5 bar, oil free, optional with protection tube
Cooling Plate	attachment or with air purge unit
Water cooling jacket	stainless steel
Protection window	quartz glass or sapphire glass

¹ other accessories on request

Optics Types

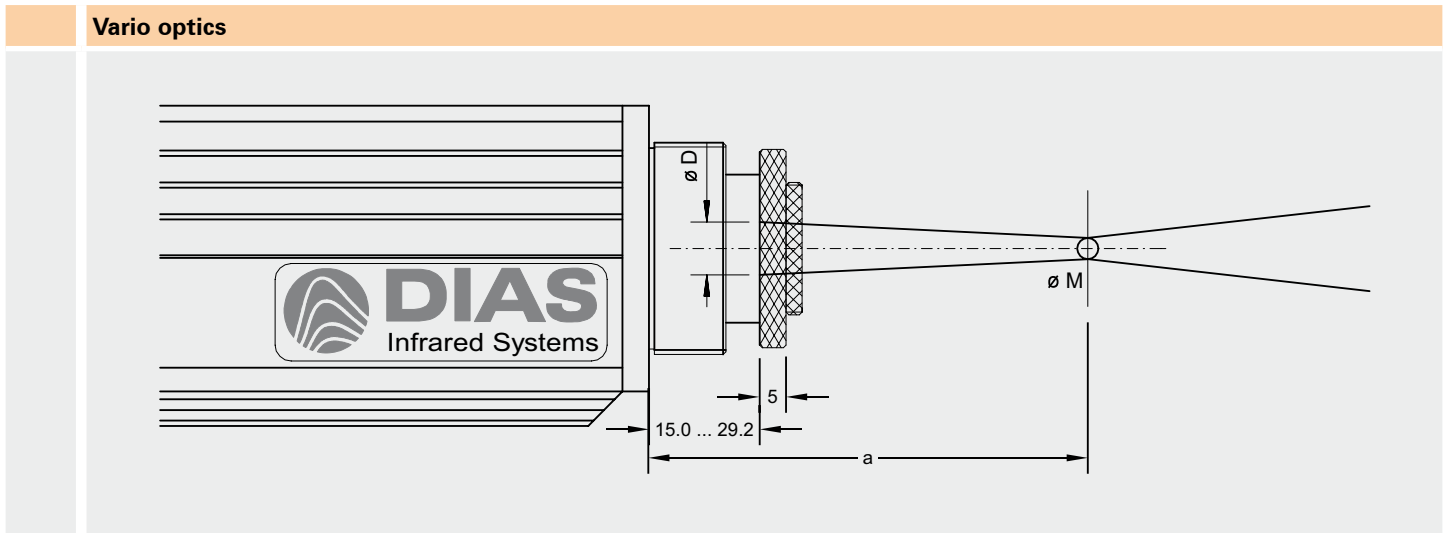
Vario optics							
Measuring distance a in mm	0	250	300	350	500	800	4000
Optics pullout in mm	0	14.2	10.5	8.5	5.3	3.0	0
Measuring field diameter M in mm							
DGE 10N (100 °C to 850 °C)	10	2.5	3.0	3.5	5.0	8.0	40
DGE 10N (150 °C to 1200 °C)	10	1.2	1.4	1.5	2.3	4.0	20



Display	Rear view
<ul style="list-style-type: none"> - Displays the actual temperature - Displays the adjusted emissivity 	<ul style="list-style-type: none"> - Through-lens sighting or aiming light push-button - Plug connector and interface - Push-buttons for adjustment of emissivity
	

Dimensions and Accessories

Dimensions pyrometer (version with through-lens sighting)

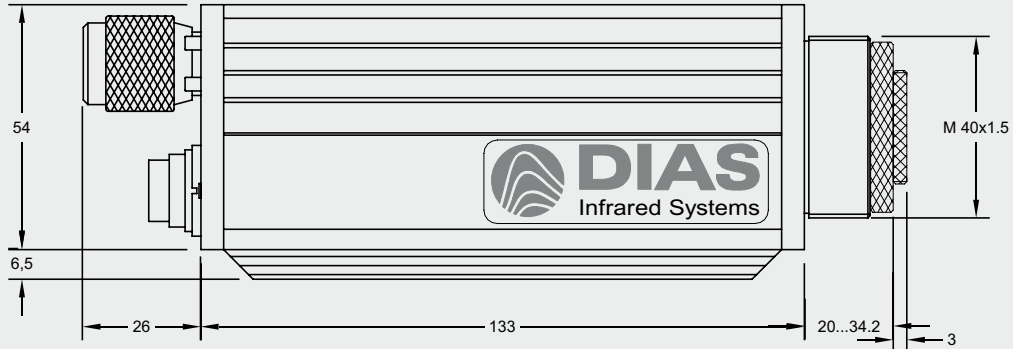

Accessories

Mounting angle, adjustable



Ball and socket mounting



Cooling jacket

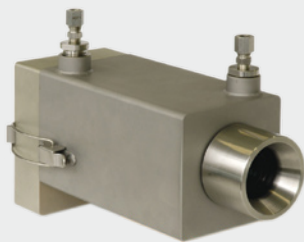

Air purge unit



Digital display DD 200 and DD 210



Power supply



Technical details are subject to change without notice. August 2010.