

PYROSPOT DGF 11N/DGEF 11N

Pyrometers with Fibre Cable for Industrial Applications



- **Digital pyrometers for 150 °C to 2500 °C**
- **Short response time 2 ms**
- **Small spot sizes from 0.7 mm**
- **RS485 interface**
- **Display and keys**

The digital pyrometers PYROSPOT DGF 11N and DGEF 11N are especially designed for industrial purpose. The devices are suitable for temperature measurement from 150 °C of many different surfaces for example metals, ceramics or graphite.

The solid body with fibre optics cable allows usage even under rough environmental conditions. The bright temperature display is visible even over long distance.

With a fast response time of only 2 ms (t95) these pyrometers are also suitable for fast measuring processes.

The vario optics for fibre optical head realizes spot sizes from 0.7 mm diameter.

The integrated red laser aiming light enables to focus the measuring object exactly.

The temperature linear standard output signal of 0/4 to 20 mA allows easy implementation in existing measuring and controlling systems.

The device is equipped with integrated, galvanically isolated RS485 interface, which allows parameterising and software evaluation even in bus systems.

All parameters are adjustable via push-buttons and display directly on the device. Also by using the comfortable parameterising and evaluation software PYROSOFT Spot the parameters can be easily adjusted to the application.

Typical application areas:

- Steel industry
- Kiln engineering
- Hardening
- Welding
- Metal industry

Technical Data and Accessories

Technical data			
Type	DGF 11N	DGF 11N	DGEF 11N
Temperature range	250 °C to 1300 °C 250 °C to 2000 °C	350 °C to 1800 °C 400 °C to 2500 °C	150 °C to 1200 °C
Sub temperature range	adjustable within temperature range, minimum span 50 °C		
Spectral range	1.5 µm to 1.8 µm		2.0 µm to 2.6 µm
Optics	FOH I or FOH II		
Distance ratio	refer table		
Measurement uncertainty ²	0.5 % of meas. value		0.5 % of meas. value + 2 K
Reproducibility ²	0.1 % of meas. value		0.1 % of meas. value + 1 K
NETD ^{1,2}	0.1 °C		0.5 °C
Response time (t ₉₅)	2 ms, adjustable up to 10 s		
Emissivity	0.050 to 1.000		
Storage	minimum-/maximum value storage		
Output	0/4 to 20 mA, adjustable via software, temperature linear, max. burden: 500 Ω		
Interface	galvanically isolated RS485 interface, half duplex, max. 115 kBd		
Software	PYROSOFT Spot for Windows®		
Aiming	laser aiming light		
Parameters	emissivity, response time, temperature unit °C or °F, storage, sub range, baud rate, address		
User controls	display and keys for parameter settings		
Power supply	24 V DC ± 25 %		
Power consumption	max. 1.5 W		
Operating temperature	0 °C to 45 °C (electronics), 0 °C to 250 °C (fibre cable and optical head)		
Storage temperature	-20 °C to 70 °C		
Weight	approx. 600 g (without fibre cable and optical head)		
Dimensions	approx. 110 mm × 80 mm × 40 mm		
Housing	cast housing with plug connector, display and keys		
Safety class	IP 65 (DIN 40 050)		
CE symbol	according to EU regulations (EN 50 011)		
Scope of delivery	PYROSPOT DGF 11N/DGEF 11N, manual, inspection sheet, Software PYROSOFT Spot for Windows® (without connecting cable, fibre cable and optical head, please order separately)		

¹ Noise equivalent temperature difference. ² T_{amb} = 23 °C, ε = 1, t₉₅ = 1s.

Accessories, mechanical, electrical and optical ¹	
Connecting cable 12-pin	length 2 m, 5 m, 10 m, 15 m, 20 m, 25 m or 30 m
Interface module	RS485 to USB
Fibre cable	length 1.5 m, 2 m, 2.5 m, 5 m, 7.5 m, 10 m, 15 m or 20 m, stainless steel clad, anti-swiveling
Power supply	24 V DC, 1 A
Mounting angle	for optical heads FOH
Air purge unit for FOH II	stainless steel, air pressure 0.1 to 0.5 bar, oil free
Mirror for FOH II	stainless steel, 90°
Protection window FOH II	quartz glass or sapphire glass

¹ Other accessories on request.

Optics Types FOH II and FOH I

Optics FOH II-65									
Measuring distance a in mm	0	65	85	110	150	200	240	300	
Measuring field diameter M in mm									
DGF 11N (250 °C to 1300 °C)	9	1.3	1.7	2.1	2.8	3.6	4.2	5.0	
DGF 11N (350 °C to 1800 °C)	9	0.7	0.9	1.1	1.4	1.8	2.1	2.5	
DGF 11N (350 °C to 2000 °C)	9	1.3	1.7	2.1	2.8	3.6	4.2	5.0	
DGF 11N (400 °C to 2500 °C)	9	0.7	0.9	1.1	1.4	1.8	2.1	2.5	
DGEF 11N (150 °C to 1200 °C)	9	1.3	1.7	2.1	2.8	3.6	4.2	5.0	

Optik FOH II-250										
Measuring distance a in mm	0	250	300	400	600	800	1000	1500	2000	2500
Measuring field diameter M in mm										
DGF 11N (250 °C to 1300 °C)	9	3.0	3.7	5.0	7.2	9.2	12	18	24	31
DGF 11N (350 °C to 1800 °C)	9	1.7	2.1	2.7	4.4	5.5	6.8	10	13	17
DGF 11N (350 °C to 2000 °C)	9	3.0	3.7	5.0	7.2	9.2	12	18	24	31
DGF 11N (400 °C to 2500 °C)	9	1.7	2.1	2.7	4.4	5.5	6.8	10	13	17
DGEF 11N (150 °C to 1200 °C)	9	3.0	3.7	5.0	7.2	9.2	12	18	24	31

Optik FOH I-100'										
Measuring distance a in mm	0	100	130	165	225	300	500	700	1000	
Measuring field diameter M in mm										
DGF 11N (250 °C to 1300 °C)	6	1.8	2.2	2.8	4.0	5.5	9.0	13	18	
DGF 11N (350 °C to 1800 °C)	6	0.9	1.1	1.4	2.0	2.7	4.5	6.5	9.0	
DGF 11N (350 °C to 2000 °C)	6	1.8	2.2	2.8	4.0	5.5	9.0	13	18	
DGF 11N (400 °C to 2500 °C)	6	0.9	1.1	1.4	2.0	2.7	4.5	6.5	9.0	
DGEF 11N (150 °C to 1200 °C)	6	1.8	2.2	2.8	4.0	5.5	9.0	13	18	

Fibre cables for optics FOH II and FOH I		
Measuring range	Diameter in μm	Clad
DGF 11N (250 °C to 1300 °C and 250 °C to 2000 °C)	400	stainless steel
DGF 11N (350 °C to 1800 °C and 400 °C to 2500 °C)	200	stainless steel
DGEF 11N (150 °C to 1200 °C)	400	stainless steel

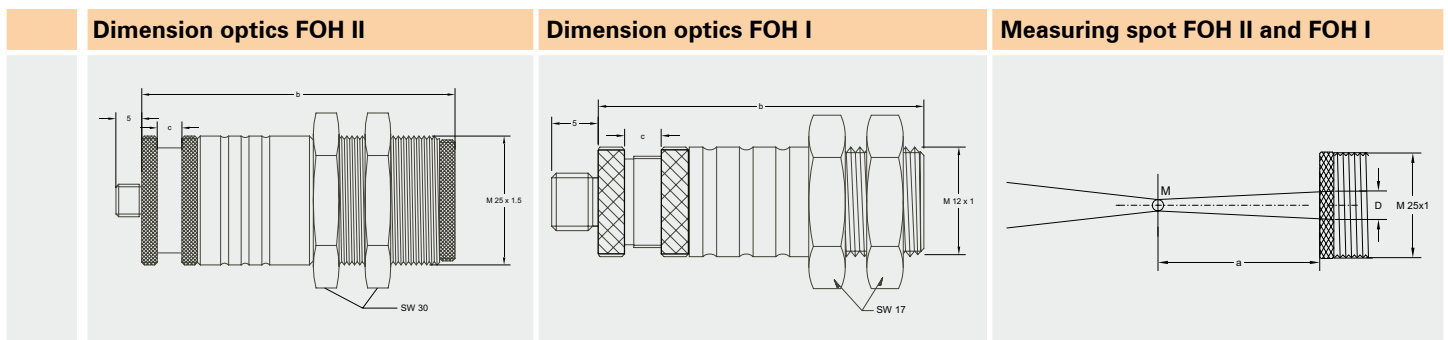

Dimensions and Accessories

Dimensions Pyrometer

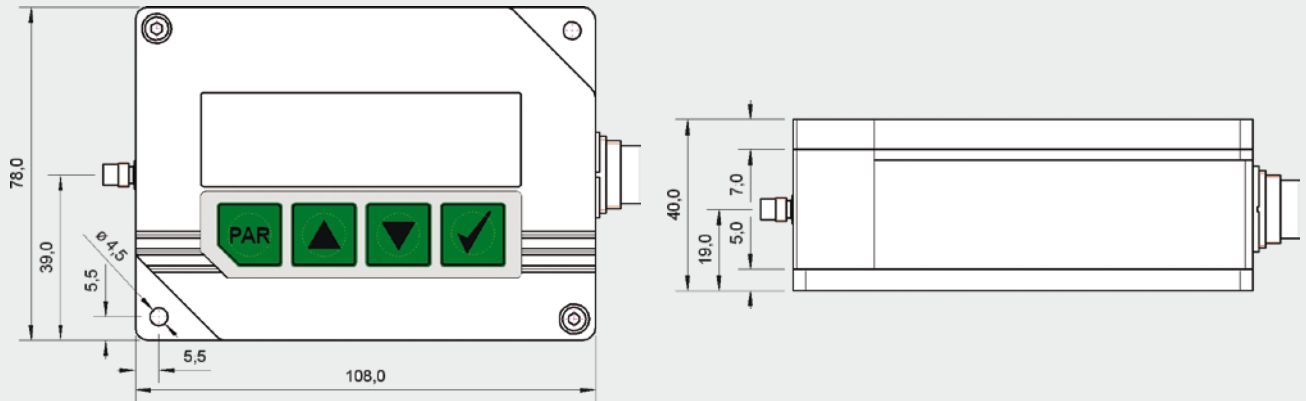

Accessories

Mounting angle, adjustable



Mounting angle, adjustable, for FOH II



Mirror 90° for FOH II



Air purge unit for FOH II (optional with protection tube)



Digital display DD 200 and DD 210



Power supply



Technical details are subject to change without notice. August 2010.